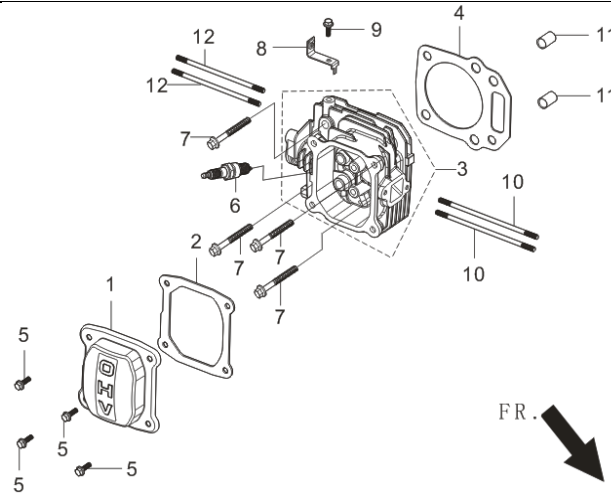

FIG.1 HEAD SUBASSEMBLY, CYLINDER / PLUG,SPARK (E04)

图1：气缸头部件/火花塞 (E04)



REF.NO. 序号	PART NO 物料代码	CHINSES 中文名	DESCRIPTION 英文名	Q'TY 数量	备注
E04-1	12411-Z030120-0000	气缸头盖	COVER, CYLINDER HEAD	1	
E04-2	12004-Z030110-0000	气缸头盖密封垫	GASKET, CYLINDER HEAD COVER	1	
E04-3	12140-Z390110-0000	气缸头组合	HEAD SUBASSEMBLY, CYLINDER	1	
E04-4	12131-Z390110-0000	气缸头密封垫	GASKET, CYLINDER HEAD	1	
E04-5	90007-0612-A1	六角法兰面螺栓-加大系列-B级	BOLT	4	
E04-6	30010-Z030310-0000	火花塞	PLUG, SPARK	1	
E04-7	12003-Z030110-0000	气缸头螺栓	BOLT, CYLINDER HEAD	4	
E04-8	18006-Z030110-0000	消声器护罩支架	BRACKET, MUFFLER SHIELD	1	
E04-9	90007-0612-A1	六角法兰面螺栓-加大系列-B级	BOLT, HEX. FLANG-LARGE SERIES-B CLASS	1	
E04-10	90204-Z390210-0000	双头螺栓	STUD	2	
E04-11	90502-1014-00	定位销-A型	PIN	2	
E04-12	90204-Z030110-0000	双头螺栓 bm=2d	STUD	2	

FIG.2 CRANKCASE.(E01)

图2：曲轴箱组件(E01)

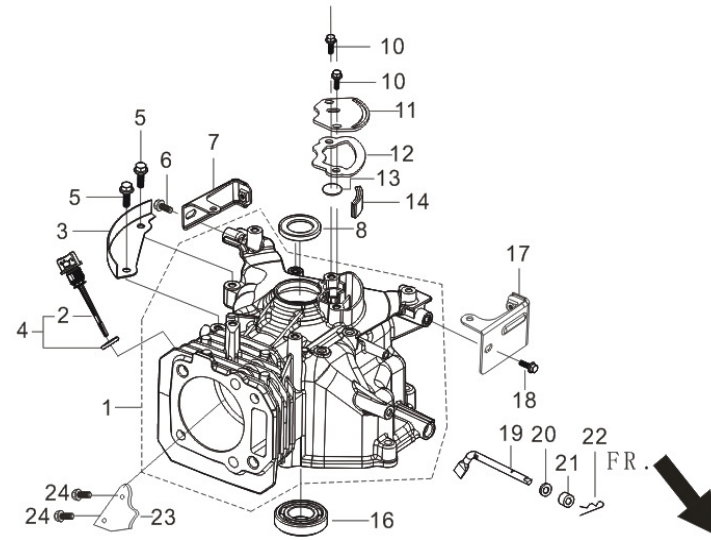

REF.NO. 序号	PART NO 物料代码	CHINSE 中文名	DESCRIPTION 英文名	Q'TY 数量	备注
E01-1	11310-Z390120-0000	曲轴箱体组合	CRANKCASE SUBASSEMBLY.	1	
E01-3	19308-Z470110-0000	箱体左侧护罩	SHIELD, CRANKCASE SIDE	1	
E01-4	15010-Z760110-Q231	机油尺组合	DIPSTICK SUBASSEMBLY, OIL	1	
E01-5	90007-0625-A1	六角法兰面螺栓-加大系列-B级	BOLT	2	
E01-6	90007-0612-A1	六角法兰面螺栓-加大系列-B级	BOLT	1	
E01-7	16607HZ470110-0000	油箱安装左支架	BRACKET, FUEL TANK RIGHT	1	
E01-8	90682-Z030120-0000	油封	SEAL, OIL	1	
E01-10	90007-0612-A1	六角法兰面螺栓-加大系列-B级	BOLT	1	
E01-11	11333-Z250210-0000	呼吸槽盖板	PLATE, BREATH GROOVE COVER	1	
E01-12	11332-Z250410-0000	呼吸槽密封垫	GASKET, BREATH GROOVE	1	
E01-13	11321-Z030110-0099	呼吸片	PIECE, BREATH	1	
E01-14	11331-Z250110-0000	呼吸槽滤网	STRAINER, BREATH GROOVE	1	
E01-16	90548-0205-CL	深沟球轴承	BEARING	1	
E01-17	16608HZ470310-0000	油箱安装右支架	BRACKET, FUEL TANK LEFT	1	
E01-18	90007-0625-A1	六角法兰面螺栓-加大系列-B级	BOLT	1	
E01-19	16061-Z030120-0000	调速臂	ARM, GOVERNOR	1	

E01-20	90408-Z010210-0000	平垫圈 A级	WASHER	1	
E01-21	90682-Z030210-0000	油封	SEAL, OIL	1	
E01-22	90501-Z010110-0000	开口销	PIN	1	
E01-23	11306-Z390110-0000	回油孔盖板		1	
E01-24	90001-0510-01	六角法兰面螺栓	BOLT	1	

FIG.3 COVER SUBASSEMBLY, CRANKCASE / GEAR ASSY, GOVERNOR(E16)

图3：曲轴箱盖部件 + 调速齿轮部件(E16)

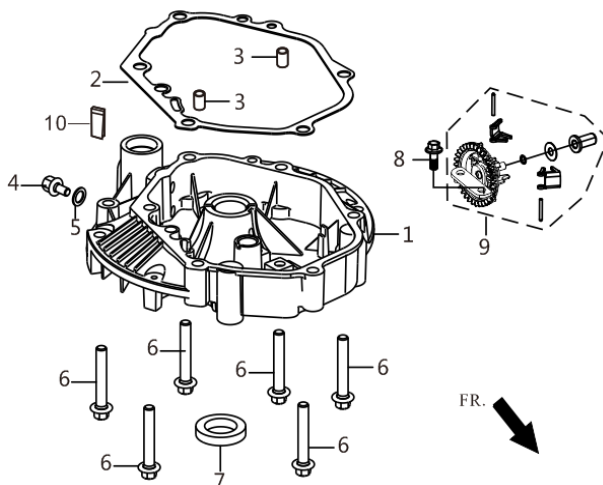

REF.NO. 序号	PART NO 物料代码	CHINSES 中文名	DESCRIPTION 英文名	Q'TY 数量	备注
E16-1	11411-Z470130-0000	曲轴箱盖	COVER, CRANKCASE	1	
E16-2	11001-Z470120-0000	曲轴箱密封垫	GASKET, CRANKCASE	1	
E16-3	90502-0812-00	定位销-A型	PIN	2	
E16-4	11007-Z010110-0000	放油螺栓		1	
E16-5	90408-Z010110-0000	平垫圈 A级	WASHER	1	
E16-6	90001-Z030310-0000	六角法兰面螺栓 小系列	BOLT	6	
E16-7	90682-Z470110-0000	油封	SEAL, OIL	1	
E16-8	90007-0612-A1	螺栓		1	
E16-9	16400-Z470230-0000	调速齿轮部件	GEAR ASSY, GOVERNOR	1	
E16-10	11341-Z030110-0000	回油块		1	

FIG.4 ROD,CRANKSHAFT CONNETING (E03)

图4：曲柄连杆组件(E03)

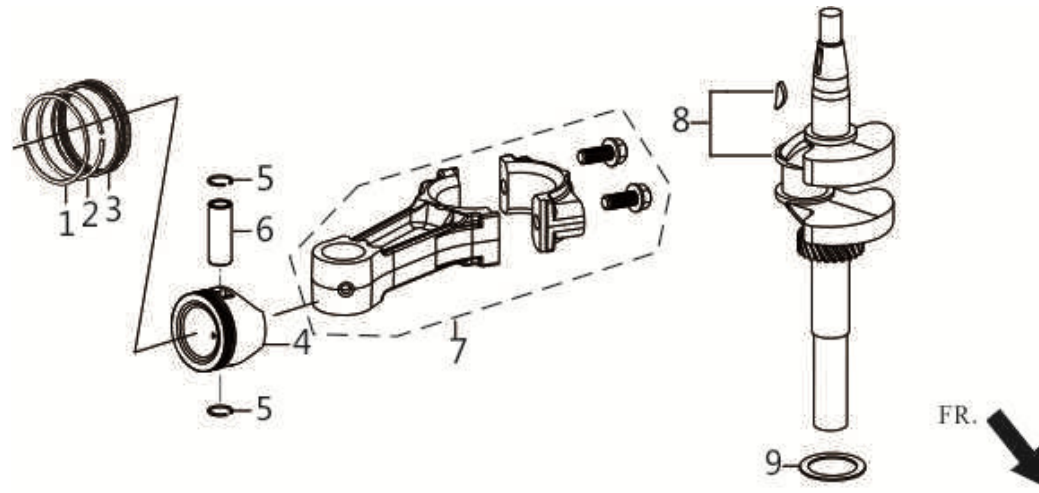

REF.NO. 序号	PART NO 物料代码	CHINSES 中文名	DESCRIPTION 英文名	Q'TY 数量	备注
E03-1 2 3	13200-Z140210-0099	活塞环部件	RING, THE FIRST	1	
E03-4	13111-Z810120-0000	活塞	PISTON	1	
E03-5	13122-Z250110-0000	活塞销卡圈	CLIP, PISTON PIN	2	
E03-6	13121-Z810110-0000	活塞销	PIN, PISTON	1	
E03-7	13010-Z390110-0000	连杆	ROD, CONNECTING	1	
E03-8	13300-Z390110-0000	曲轴部件	CRANKSHAFT ASSY.	1	
E03-9	90408-Z030210-0000	平垫圈	WASHER	1	

FIG.5 TRAIN,VALVE / CAMSHAFT SUBASSEMBLY (E05)

图5：配气机构组件/凸轮轴（E05）

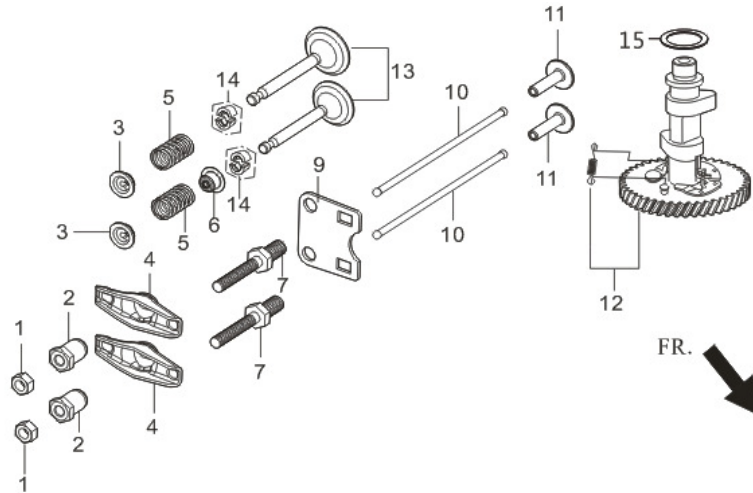

REF.NO. 序号	PART NO 物料代码	CHINSE 中文名	DESCRIPTION 英文名	Q'TY 数量	备注
E05-1	14312-Z010110-0000	气门锁紧螺母	NUT, VALVE LOCK	2	
E05-2	14314-Z010110-0000	气门调节螺母	NUT , VALVE ADJUSTING	2	
E05-3	12112-Z810110-0000	气门弹簧座	SEAT, VALVE SPRING	2	
E05-4	14311-Z250110-0000	气门摇臂	ROCKER, VALVE	2	
E05-5	12103-Z030110-0000	气门弹簧	SPRING, VALVE	2	
E05-6	12101-Z810210-0000	挡油罩	GUIDE, SEAL	1	
E05-7	14313-Z010110-0000	摇臂轴螺栓	BOLT, VALVE ADJUSTING	2	
E05-9	14090-Z030110-0000	挺杆限位板组合	PLATE SUBASSEMBLY, LIFTER STOPPER	1	
E05-10	14071-Z390110-0000	气门挺杆	LIFTER, VALVE	2	
E05-11	14081-Z250110-0000	气门挺柱	TAPPET, VALVE	2	
E05-12	14200-Z390210-0000	凸轮轴部件	CAMSHAFT ASSY.	1	
E05-13	12110-Z390110-0000	气门组件	VALVE	1	
E05-14	12109-Z810110-0000	气门锁夹			
E05-15	90408-Z470210-0000	平垫圈	WASHER	1	

FIG.6 STARTER,RECOIL (E08)

图6：手起动组件 (E08)

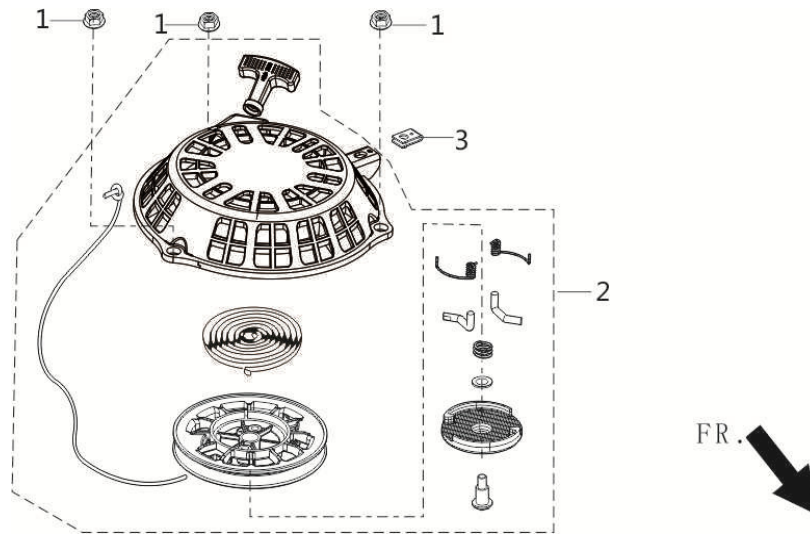

REF.NO. 序号	PART NO 物料代码	CHINSES 中文名	DESCRIPTION 英文名	Q'TY 数量	备注
E08-1	90305-0600-31	六角法兰面螺母	NUT	3	
E08-2	28200-Z251710-Q200	手起动部件	STARTER ASSY, RECOIL	1	

FIG.7 SHIELD, FAN (E14)

图7：导流罩（E14）

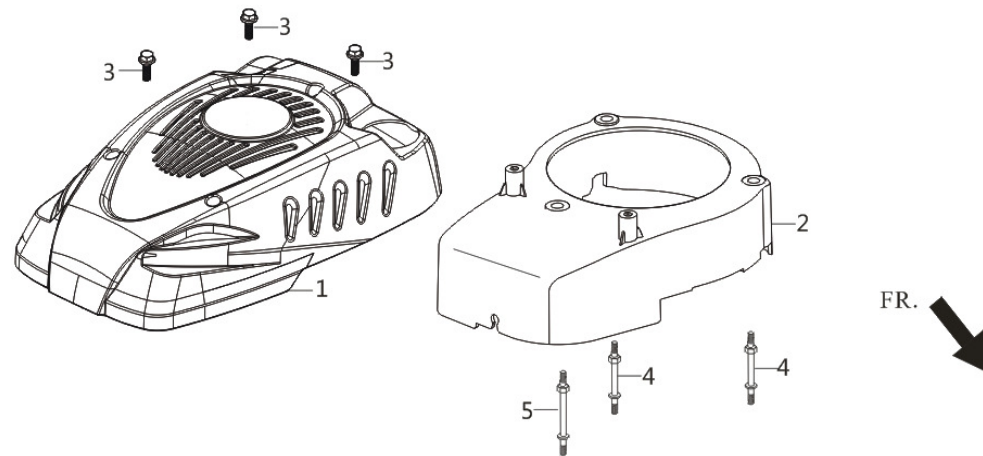

REF.NO. 序号	PART NO 物料代码	CHINSES 中文名	DESCRIPTION 英文名	Q'TY 数量	备注
E14-1	80001-Z030110-Q200	发动机外罩	HOUSING, ENGINE	1	
E14-2	28110-Z470130-0000	导风罩	SHROUD	1	
E14-3	90001-0514-01	六角法兰面螺栓	BOLT	3	
E14-4	28001-Z470210-0000	双头支撑螺栓	STUD	2	
E14-5	28001-Z470110-0000	双头支撑螺栓	STUD	1	

FIG.8 CARBURETOR ASSY. (E11)

图8：化油器部件 (E11)

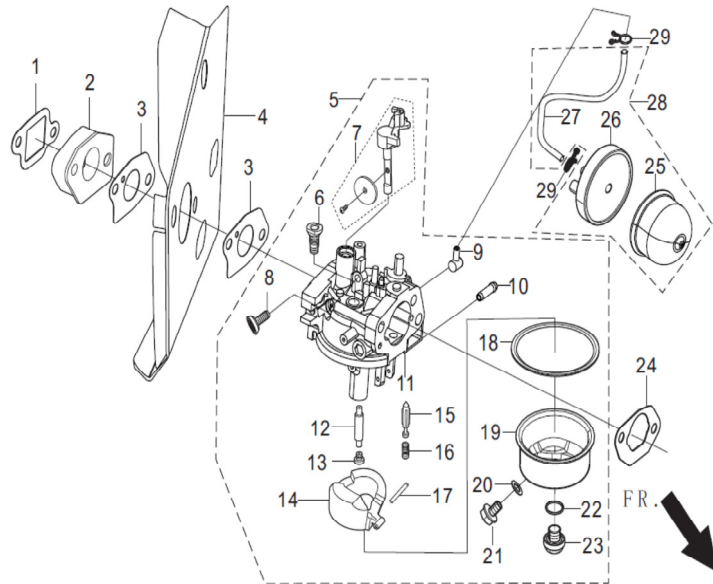

REF.NO. 序号	PART NO 物料代码	CHINSES 中文名	DESCRIPTION 英文名	Q'TY 数量	备注
E11-1	16004-Z030110-0000	隔热板密封垫	GASKET, INSULATOR PLATE	1	
E11-2	16003-Z030110-0000	化油器隔热板	PLATE, CARBURETOR INSULATOR	1	
E11-3	16001-Z010110-0000	化油器密封垫	GASKET, CARBURETOR	2	
E11-4	16002-Z340410-0000	化油器隔热垫	GASKET, CARBURETOR INSULATOR	1	
E11-5	16100-Z390310-0000	化油器部件	CARBURETOR ASSY.	1	
E11-24	17001-Z030120-0000	空滤器密封垫	GASKET, AIR CLEANER	1	
E11-27	16211-Z250110-0000	起动加浓阀管	TUBE, STARTING RICHED VALVE	1	
E11-28	16210-Z250120-0030	起动加浓阀	VALVE, STARTING RICHED	1	
E11-29	90685-0700-01	管夹	CLAMP	2	

FIG.9 CLEANER, AIR (F02)

图9：空滤器（F02）

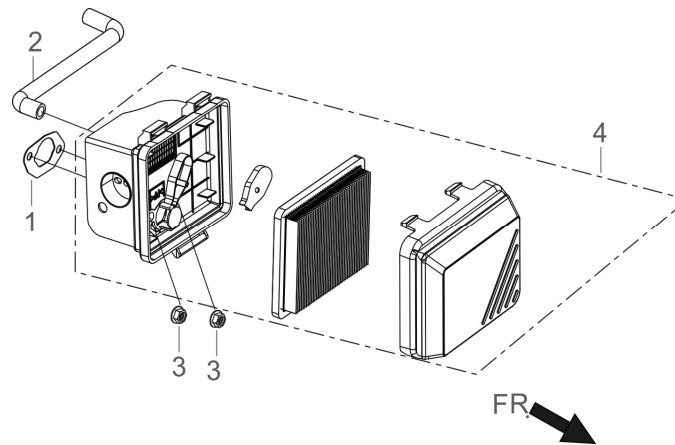

REF.NO. 序号	PART NO 物料代码	CHINSES 中文名	DESCRIPTION 英文名	Q'TY 数量	备注
F02-1	17001-Z030120-0000	空滤器密封垫	GASKET, AIR CLEANER	1	
F02-2	17004-Z030310-0000	废气管	TUBE, BREATHER	1	
F02-3	90305-0600-31	六角法兰面螺母	NUT	1	
F02-4	17100-Z250230-0000	空滤器	CASE, AIR CLEANER	1	

FIG.10 MUFFLER (F04)

图10 : 消声器 (F04)

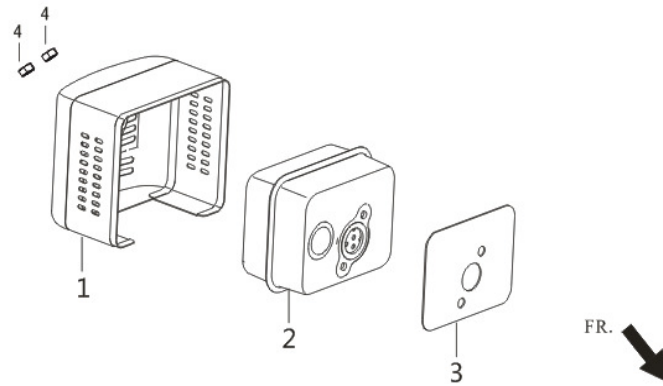

REF.NO. 序号	PART NO 物料代码	CHINSES 中文名	DESCRIPTION 英文名	Q'TY 数量	备注
F04-1	18130-Z390210-QB00	消声器外罩	COVER, MUFFLER OUTER	1	
F04-2	18100-Z340210-QA01	消声器部件	MUFFLER ASSY.	1	
F04-3	18001-Z340210-0000	排气口密封垫		1	
F04-4	90310-0600-31	全金属六角法兰面锁紧螺母		2	

FIG.11 TANK, FUEL (F01)

图11 : 油箱 (F01)

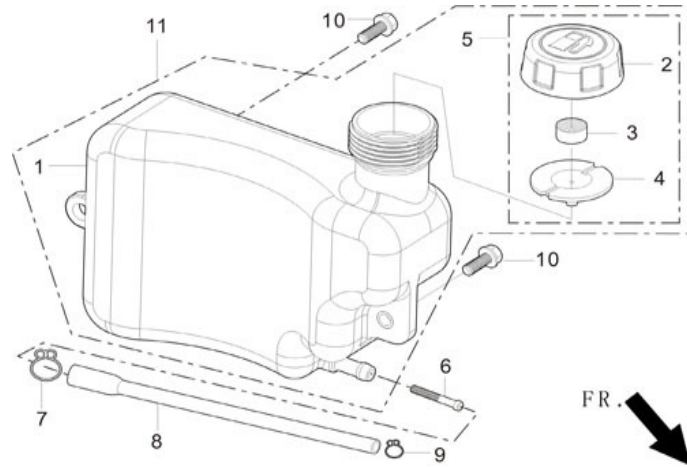

REF.NO. 序号	PART NO 物料代码	CHINSES 中文名	DESCRIPTION 英文名	Q'TY 数量	备注
F01-6	16652-Z030110-0000	燃油滤网	STAINER, FUEL	1	
F01-7	90685-Z030410-0000	管夹	CLIP	1	
F01-8	90686-Z030310-0000	油管	TUBE, FUEL	1	
F01-9	90685-Z030220-0000	卡箍	COLLAR	1	
F01-10	90007-0614-A1	六角法兰面螺栓-加大系列-B级	BOLT, HEX. FLANG-LARGE SERIES-B CLASS	1	
F01-11	16600-Z030110-Q200	油箱部件	TANK ASSY, FUEL	1	

FIG.12 FLYWHEEL / IMPELLER / STARTER PULLEY / IGNITION COIL (E15)

图12：飞轮/叶轮/启动杯/点火线圈（E15）

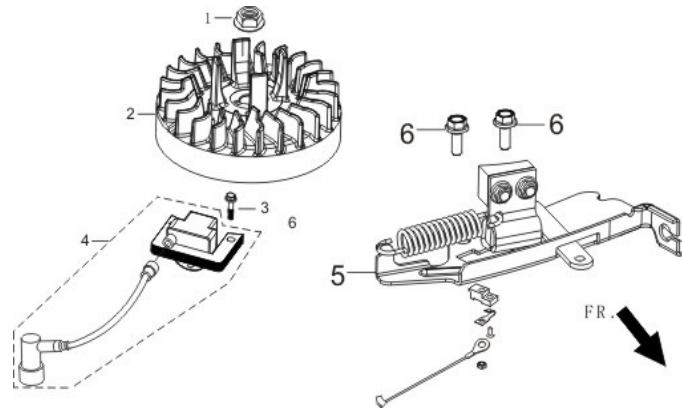

REF.NO. 序号	PART NO 物料代码	CHINSES 中文名	DESCRIPTION 英文名	Q'TY 数量	备注
E15-1	13501-Z010110-0000	飞轮螺母	NUT, FLYWHEEL	1	
E15-2	13510-Z030110-0000	飞轮组合	FLYWHEEL SUBASSEMBLY	1	
E15-3	90007-0625-A1	六角法兰面螺栓-加大系列-B级	BOLT, HEX. FLANG-LARGE SERIES-B CLASS	1	
E15-4	30400-Z340410-0000	点火线圈	COIL, IGNITION	1	
E15-5	45200-Z390110-0000	制动器部件	BRAKE ASSY.	1	
E15-6	90007-0612-A1	六角法兰面螺栓	BOLT, HEX. FLANG-LARGE SERIES-B CLASS	1	

FIG.13 CONTROL ASSY, THROTTLE (E13)

图13 : 油门操纵部件 (E13)

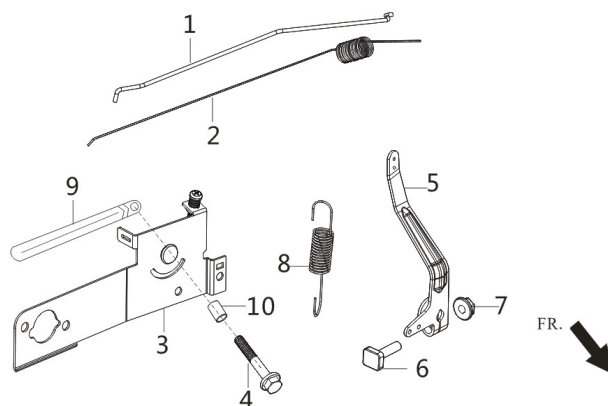

REF.NO. 序号	PART NO 物料代码	CHINSES 中文名	DESCRIPTION 英文名	Q'TY 数量	备注
E13-1	16062-Z470110-0000	调速拉杆	ROD, GOVERNEOR	1	
E13-2	16012-Z470110-0000	节气门复位弹簧	SPRING, THROTTLE	1	
E13-3	16520-Z470210-0000	油门操纵组合	CONTROL ASSY, THROTTLE	1	
E13-4	90007-0628-A1	六角法兰面螺栓-加大系列-B级	BOLT, HEX. FLANG-LARGE SERIES-B CLASS	1	
E13-5	16070-Z030130-0000	调速支架组合	SUPPORT SUBASSEMBLY, GOVERNOR	1	
E13-6	16072-Z010110-0000	调速支架固定螺栓	BOLT, GOVERNOR SUPPORT	1	
E13-7	90305-0600-31	六角法兰面螺母	NUT, HEX. FLANGE	1	
E13-8	16063-Z340110-0000	调速弹簧	SPRING, GOVERNOR	1	
E13-9	90684-Z030120-0000	线夹	CLIP	1	
E13-10	90683-Z340110-0000	衬套	BUSH	1	

