

RT50ZB26-3.6Q 图册

FIG.1 HEAD SUBASSEMBLY, CYLINDER / PLUG,SPARK(E04)

图 1 : 气缸头部件/火花塞 (E04)

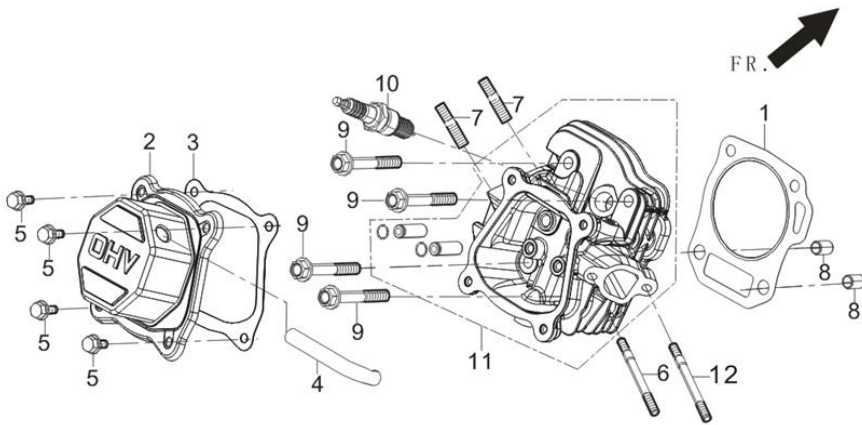

WORK HOURS 工时

1、 GASKET, CYLINDER HEAD.....	0.5H
1、 气缸头密封垫.....	0.5H
2、 COVER SUBASSEMBLY, CYLINDER HEAD.....	0.1H
2、 气缸头盖组合.....	0.1H
3、 GASKET, CYLINDER HEAD COVER.....	0.1H
3、 气缸头盖密封垫.....	0.1H
10、 PLUG, SPARK.....	0.1H
10、 火花塞.....	0.1H
11、 HEAD SUBASSEMBLY, CYLINDER.....	0.9H
11、 气缸头组合.....	0.9H

REF. NO. 序号	PART NO 物料代码	CHINSES 中文名	DESCRIPTION 英文名	Q'TY 数量	包装数	备注
E04-1	12131-Z950110-0000	气缸头密封垫	GASKET, CYLINDER HEAD	1	1	
E04-2	12410-Z440210-H399	气缸头盖组合	COVER SUBASSEMBLY, CYLINDER HEAD	1	1	
E04-3	12004-Z440210-0000	气缸头盖密封垫	GASKET, CYLINDER HEAD COVER	1	1	
E04-4	17004-Z440110-0000	废气管	TUBE, BREATHER	1	1	
E04-5	90001-0612-03	六角法兰面螺栓-小系列	BOLT	4	1	

E04-6	90204-Z010310-0000	双头螺柱	STUD	1	1	
E04-7	90203-Z010110-0000	双头螺柱	STUD	2	1	
E04-8	90502-1114-00	定位销-A 型	PIN	2	1	
E04-9	12003-Z010110-0000	气缸头螺栓	BOLT, CYLINDER HEAD	4	1	
E04-10	30010-Z010110-0000	火花塞	PLUG, SPARK	1	1	
E04-11	12140-Z440310-0000	气缸头组合	HEAD SUBASSEMBLY, CYLINDER	1	1	
E04-12	90207-Z330210-0000	双头螺柱	STUD	1	1	

FIG.2 CRANKCASE. / GEAR ASSY, GOVERNOR.(E17)

图 2 曲轴箱体部件 + 调速齿轮部件(E17)

	WORK HOURS 工时
	<p>1、CRANKCASE ASSY.....1.2H</p> <p>1、曲轴箱体组合.....1.2H</p> <p>3、GEAR ASSY, GOVERNOR.....1.0H</p> <p>3、调速齿轮部件.....1.0H</p> <p>4、ARM, GOVERNOR.....0.9H</p> <p>4、调速臂.....0.9H</p> <p>7、BEARING.....1.2H</p> <p>7、深沟球轴承.....1.2H</p> <p>8、SEAL, OIL.....</p>

				1.2H 8、油 封.....1.2H	
REF. NO. 序号	PART NO 物料代码	CHINSES 中文名	DESCRIPTION 英文名	Q'TY 数量	包装数	备注
E17-1	11310-Z530220-0000	曲轴箱体组合	CRANKCASE SUBASSEMBLY.	1	1	
E17-2	37060-Z010120-0000	机油传感器	SENSOR, ENGINE OIL	1	1	
E17-3	16400-Z010110-0000	调速齿轮部件	GEAR ASSY, GOVERNOR	1	1	
E17-4	16061-Z010110-0000	调速臂	ARM, GOVERNOR	1	1	
E17-5	11007-Z010110-0000	放油螺栓	BOLT, DRAIN PLUG	2	1	
E17-6	90408-Z010110-0000	平垫圈	WASHER	2	1	
E17-7	90548-0205-CL	深沟球轴承	BEARING	1	1	
E17-8	90682-Z300110-0000	油封	SEAL, OIL	1	1	
E17-9	90305-Z010210-01	六角法兰面螺母	NUT	1	1	
E17-10	90408-Z010210-0000	平垫圈	WASHER	1	1	
E17-11	90501-Z010110-0000	开口销	PIN	1	1	
E17-12	90001-0614-01	六角法兰面螺栓	BOLT	2	1	

FIG.3 COVER SUBASSEMBLY, CRANKCASE (E01)

图 3 : 曲轴箱盖部件(E01)

WORK HOURS 工时

1、COVER, CRANKCASE.....0.2H
0.2H
 1、曲轴箱盖.....0.2H

2、BEARING, CRANKSHAFT : REAR.....0.4H
 2、轴 承.....0.4H

3、OIL SEAL, CRANKSHAFT : REAR.....0.3H
 3、油 封.....0.3H

4、GASKET, CRANKCASE.....0.2H
 4、曲轴箱密封 垫.....0.2 H

REF. NO. 序号	PART NO 物料代码	CHINSES 中文名	DESCRIPTION 英文名	Q'TY 数量	包装数	备注
E01-1	11411-Z440410-0000	曲轴箱盖	COVER, CRANKCASE	1	1	
E01-2	90548-0205-CL	深沟球轴承	BEARING	1	1	
E01-3	90682-Z300110-0000	油封	SEAL, OIL	1	1	
E01-4	11001-Z440110-0000	曲轴箱密封垫	GASKET, CRANKCASE	1	1	
E01-5	90502-0912-00	定位销	PIN	2	1	
E01-6	15010-Z010130-Q500	机油尺组合	DIPSTICK SUBASSEMBLY, OIL	1	1	
E01-7	15030-Z010130-Q500	机油塞组合	PLUG SUBASSEMBLY, ENGINE OIL	1	1	

E01-8	90001-0832-01	六角法兰面螺栓	BOLT	6	1	
-------	---------------	---------	------	---	---	--

FIG.4 ROD,CRANKSHAFT CONNETING(E03)

图 4 : 曲柄连杆组件(E04)

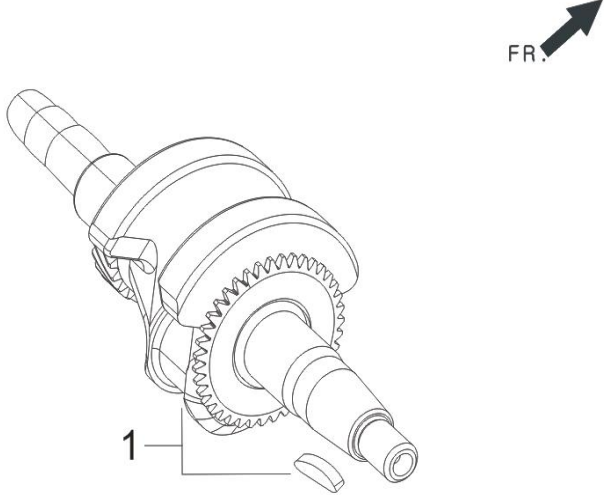
	<p>WORK HOURS 工时</p> <p>1、CRANKSHAFT ASSY.....1.1H 1、曲轴部件..... ...1.1H</p>
---	---

REF. NO. 序号	PART NO 物料代码	CHINSES 中文名	DESCRIPTION 英文名	Q'TY 数量	包装数	备注
E03-1	13300-Z530210-0000	曲轴部件	CRANKSHAFT ASSY.	1	1	

FIG.5 RING SET,OIL / ROD,CRANKSHAFT CONNETING (E03)

图 5 : 油环组合/曲柄连杆组件 (E03)

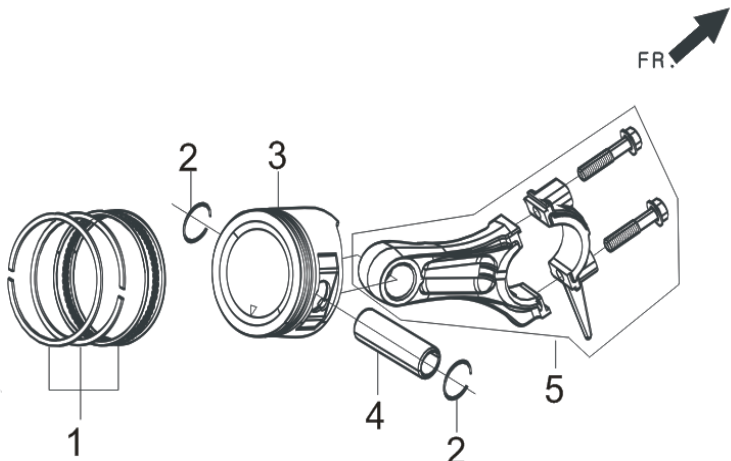
	<p>WORK HOURS 工时</p> <p>1-5、PISTON RINGS SET AND/OR CLIP, PISTON PIN AND/ OR PISTON ASSY. AND/OR PIN, PISTON AND/OR ROD, CONNECTING.....1.1H 1-5、活塞/一环/二环/活塞销/连杆.....1.1H INCLUDES : Inspection/Measurement/Cleaning 含：检查/测量/清洗</p>
---	---

REF. NO. 序号	PART NO 物料代码	CHINSES 中文名	DESCRIPTION 英文名	Q'TY 数量	包装数	备注
E03-1	13200-Z140210-0099	活塞环部件	PISTON RINGS SET	1	1	
E03-2	13122-Z010110-0000	活塞销卡圈	CLIP, PISTON PIN	2	1	
E03-3	13111-Z140220-0099	活塞	PISTON ASSY.	1	1	
E03-4	13121-Z010110-0000	活塞销	PIN, PISTON	1	1	
E03-5	13010-Z440210-0099	连杆	ROD, CONNECTING	1	1	

FIG.6 TRAIN,VALVE / CAMSHAFT SUBASSEMBLY (E05)

图 6 : 配气机构组件/凸轮轴 (E05)

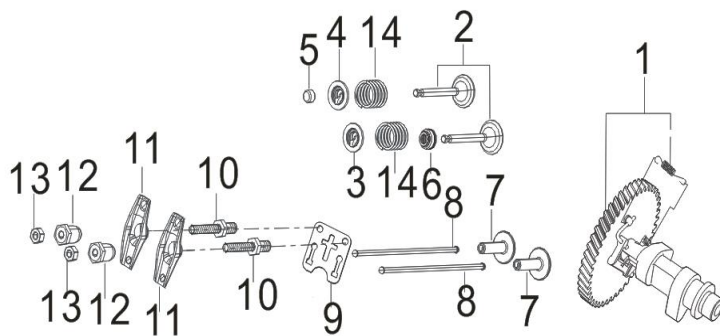

WORK HOURS 工时

1、CAMSHAFT ASSY.....	0.4H
INCLUDES:Valve clearance adjustment	
1、凸轮轴部件.....	0.4H
2、VALVES SET.....	..1H
2、气门组件.....	1H
INCLUDES:Valve clearane adjustment and reface	
replace intake and exhaust all	0.1
5、ROTATOR,VALVE.....0.2H
5、气门调整帽.....0.2H
INCLUDES:Valve clearance adjustment	
含：气门间隙调整	
7、TAPPET, VALVE.....	..0.7H
7、气门挺	

				柱..... 0.7H INCLUDES:Valve clearance adjustment 含：气门间隙调整 8、LIFTER, VALVE..... ..0.4H 8、气门挺 杆..... 0.4H INCLUDES:Valve clearance adjustment NOTE:Same time for two unit		
REF. NO. 序号	PART NO 物料代码	CHINSES 中文名	DESCRIPTION 英文名	Q'TY 数量	包装数	备注
E05-1	14200- Z440110- 0000	凸轮轴部件	CAMSHAFT ASSY.	1	1	
E05-2	12110- Z010110- 0000	气门组件	VALVES SET	1	1	
E05-3	12112- Z010110- 0000	气门弹簧座	SEAT, VALVE SPRING	1	1	
E05-4	12107- Z010110- 0000	排气门弹簧座	RETAINER, EXHAUST VALVE	1	1	
E05-5	12104- Z010110- 0000	气门调整帽	ROTATOR, VALVE	1	1	
E05-6	12101- Z010110- 0000	挡油罩	GUIDE, SEAL	1	1	
E05-7	14081- Z440110- 0000	气门挺柱	TAPPET, VALVE	2	1	
E05-8	14071- Z440110- 0000	气门挺杆	LIFTER, VALVE	2	1	
E05-9	14090- Z010110- 0000	挺杆限位板组 合	PLATE SUBASSEMBLY, LIFTER STOPPER	1	1	

E05-10	14313-Z010110-0000	摇臂轴螺栓	BOLT, VALVE ADJUSTING	2	1	
E05-11	14311-Z010110-0000	气门摇臂	ROCKER, VALVE	2	1	
E05-12	14314-Z010110-0000	气门调节螺母	NUT, VALVE ADJUSTING	2	1	
E05-13	14312-Z010110-0000	气门锁紧螺母	NUT, VALVE LOCK	2	1	
E05-14	12103-Z010110-0000	气门弹簧	SPRING, VALVE	2	1	

FIG.7 STARTER,RECOIL (E08)

图 7 : 手起动组件 (E08)

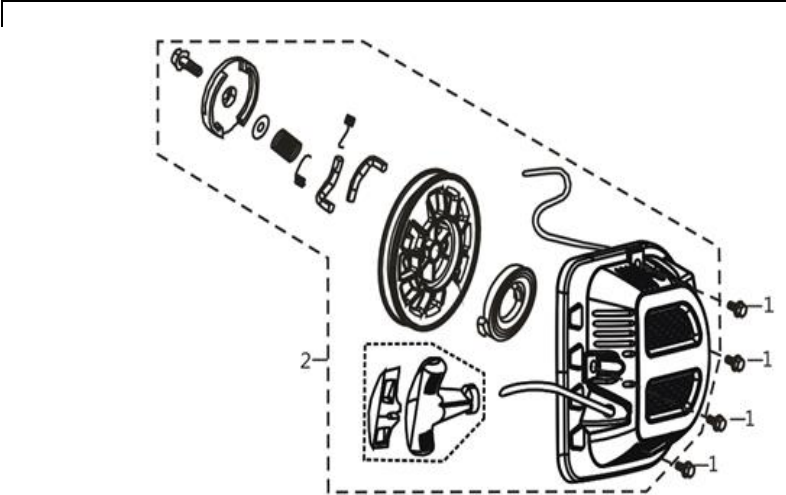
	WORK HOURS 工时
	2、STARTER ASSY, RECOIL.....0.1 H 2、手起动部件.....0.1 H

REF. NO. 序号	PART NO 物料代码	CHINSES 中文名	DESCRIPTION 英文名	Q'TY 数量	包装数	备注
E08-1	90001-0612-01	六角法兰面螺栓-小系列	BOLT	4	1	
E08-2	28200-Z010320-Q200	手起动部件	STARTER ASSY, RECOIL	1	1	

FIG.8 SHROUD / SHIELD,LOWER (E14)

图 8 : 缸体导风罩/下护罩 (E14)

WORK HOURS 工时

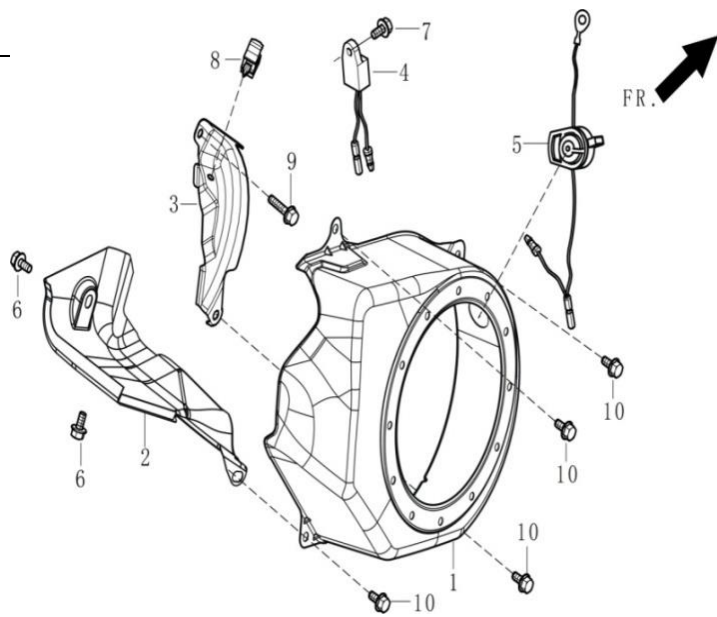

- 1、SHROUD.....0.2H
- 1、导风罩.....0.2H
- 2、SHROUD, CYLINDER BODY.....0.2H
- 2、缸体导风罩.....0.2H
- 3、SHIELD, LOWER.....0.3H
- 3、下护罩.....0.3H
- 5、SWITCH SUBASSEMBLY, STOP ENGINE.....0.2H
- 5、熄火开关组合.....0.2H

REF. NO. 序号	PART NO 物料代码	CHINSES 中文名	DESCRIPTION 英文名	Q'TY 数量	包装数	备注
E14-1	28110-Z010410-H700	导风罩	SHROUD	1	1	
E14-2	19304-Z010610-0000	缸体导风罩	SHROUD, CYLINDER BODY	1	1	
E14-3	19340-Z010120-0000	下护罩	SHIELD, LOWER	1	1	
E14-4	37050-Z010210-0000	机油保护器	PROTECTOR, OIL	1	1	
E14-5	35540-Z060140-QG00	熄火开关组合	SWITCH SUBASSEMBLY, STOP ENGINE	1	1	
E14-6	90001-0610-01	六角法兰面螺栓-小系列	BOLT	2	1	
E14-7	90001-0610-01	六角法兰面螺栓-小系列	BOLT	1	1	
E14-8	90740-Z010110-0000	卡箍	COLLAR	1	1	
E14-9	90001-0616-01	六角法兰面螺栓	BOLT	1	1	
E14-10	90001-0612-03	六角法兰面螺栓-小系列	BOLT	4	1	

FIG.9 CARBURETOR ASSY. (E11)

图 9 : 化油器部件 (E11)

	WORK HOURS 工时		
	<p>1、CARBURETOR ASSY.....0.2H 1、化油器部件.....0.2H 3/5、GASKET, CARBURETOR AND/OR GASKET, CARBURETOR INSULATOR.....0.2H 3/5、化油器密封垫/隔热垫.....0.2H 4、PLATE, CARBURETOR INSULATOR.....0.2H 4、化油器隔热板.....0.2H</p>		

REF. NO. 序号	PART NO 物料代码	CHINSES 中文名	DESCRIPTION 英文名	Q'TY 数量	包装数	备注
E11-1	16100-Z530210-0000	化油器部件	CARBURETOR ASSY.	1	1	
E11-2	17001-Z010210-0000	空滤器密封垫	GASKET, AIR CLEANER	1	1	
E11-3	16001-Z010110-0000	化油器密封垫	GASKET, CARBURETOR	1	1	
E11-4	16003-Z010110-0000	化油器隔热板	PLATE, CARBURETOR INSULATOR	1	1	
E11-5	16002-Z050110-0000	化油器隔热垫	GASKET, CARBURETOR INSULATOR	1	1	

FIG.10 CLEANER, AIR (F02)

图 10 : 空滤器 (F02)

	WORK HOURS 工时
--	---------------

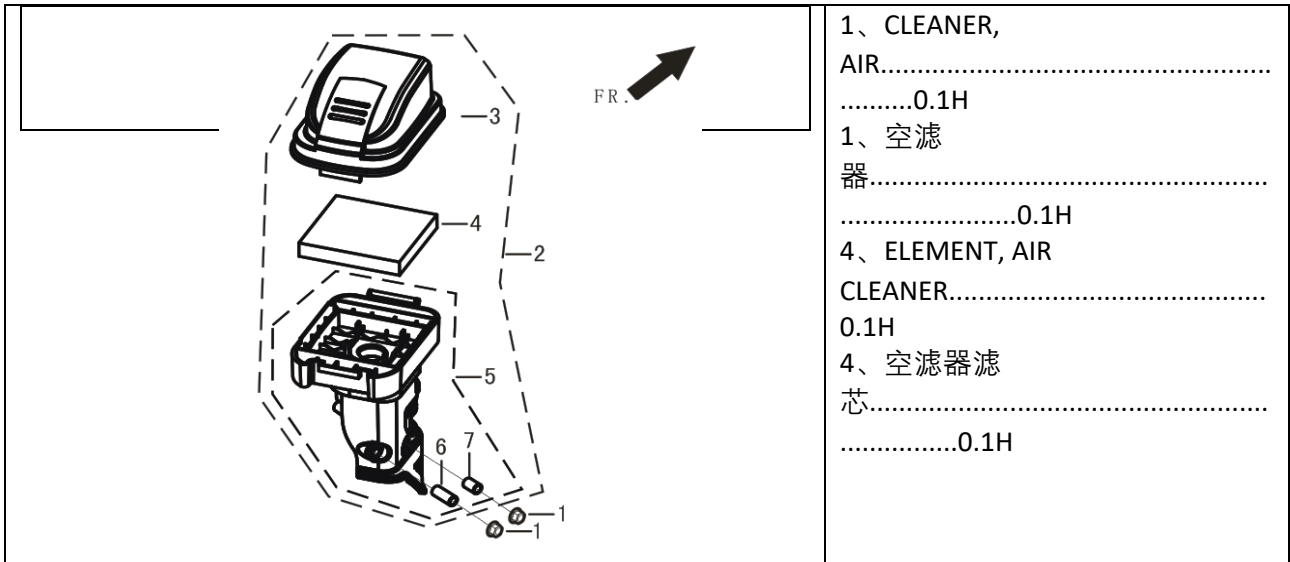

1、CLEANER,
AIR.....0.1H
1、空滤
器.....0.1H
4、ELEMENT, AIR
CLEANER.....0.1H
4、空滤器滤
芯.....0.1H

REF. NO. 序号	PART NO 物料代码	CHINSES 中文名	DESCRIPTION 英文名	Q'TY 数量	包装数	备注
F02-1	90305-0600-31	六角法兰面螺母	NUT	2	1	
F02-2	17100-Z440220-0099	空滤器	CLEANER, AIR	1	1	
F02-3	17104-Z440110-0000	空滤器壳体盖	COVER, AIR CLEANER CASE	1	1	空滤器拆分件
F02-4	17151-Z440110-0000	空滤器滤芯	ELEMENT SUBASSEMBLY, AIR CLEANER	1	1	
F02-5	17140-Z440210-0000	空滤器座体组合	ELBOW SUBASSEMBLY, AIR CLEANER	1	1	

FIG.11 MUFFLER ASSY. (F04)

图 11 : 消声器部件 (F04)

WORK HOURS 工时

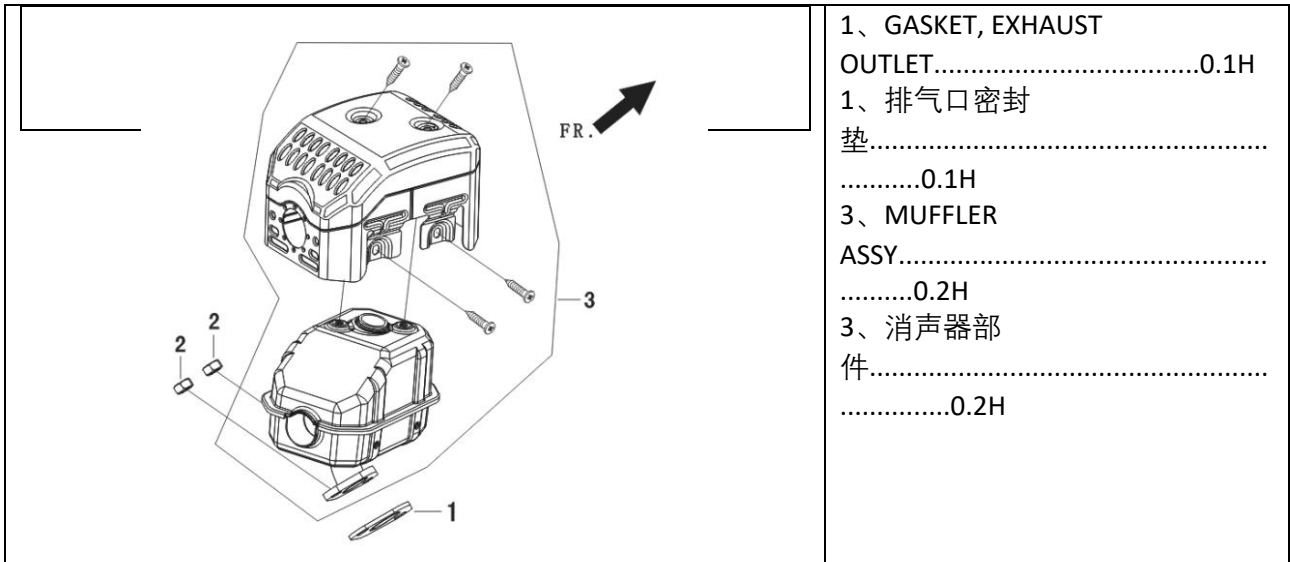

1、GASKET, EXHAUST
OUTLET.....0.1H
1、排气口密封
垫.....
.....0.1H
3、MUFFLER
ASSY.....
.....0.2H
3、消声器部
件.....
.....0.2H

REF. NO. 序号	PART NO 物料代码	CHINSES 中文名	DESCRIPTION 英文名	Q'TY 数量	包装数	备注
F04-1	18001-Z440110-0000	排气口密封垫	GASKET, EXHAUST OUTLET	1	1	
F04-2	90303-0800-31	1 型六角螺母	NUT	2	1	
F04-3	18100-Z442810-H300	消声器部件	MUFFLER ASSY	1	1	

FIG.12 TANK ASSY, FUEL (F01)

图 12 : 油箱部件 (F01)

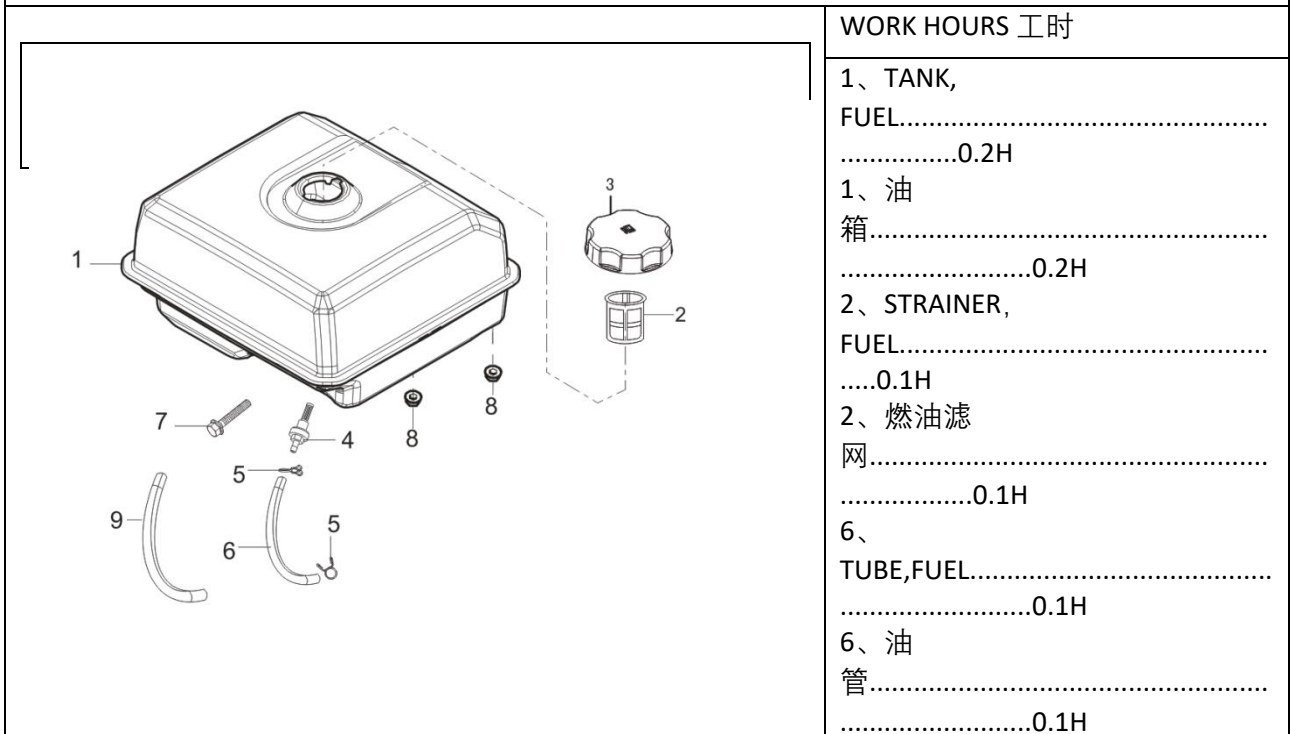

WORK HOURS 工时
1、TANK,
FUEL.....
.....0.2H
1、油
箱.....
.....0.2H
2、STRAINER,
FUEL.....
.....0.1H
2、燃油滤
网.....
.....0.1H
6、
TUBE,FUEL.....
.....0.1H
6、油
管.....
.....0.1H

REF. NO. 序号	PART NO 物料代码	CHINSES 中文名	DESCRIPTION 英文名	Q'TY 数量	包装数	备注
F01-1	16620-Z440120-H700	油箱	TANK, FUEL	1	1	
F01-2	16652-Z010610-0000	燃油滤网	STRAINER, FUEL	1	1	
F01-3	16730-Z440120-0000	油箱盖	COVER, FUEL TANK	1	1	
F01-4	16680-Z010110-0000	出油嘴组合	OUTLET SUBASSEMBLY, FUEL TANK OIL	1	1	
F01-5	90740-Z010210-0000	卡箍	CLAMP	2	1	
F01-6	90686-Z010710-0000	油管	TUBE, FUEL	1	1	
F01-7	90001-0630-01	六角法兰面螺栓	BOLT	1	1	
F01-8	90305-0600-31	六角法兰面螺母	NUT	2	1	
F01-9	30431-Z010110-0000	橡胶护套	JACKET, RUBBER	1	1	

FIG.13 FLYWHEEL / IMPELLER / STARTER PULLEY / IGNITION COIL (E15)

图 13 : 飞轮/叶轮/启动杯/点火线圈 (E15)

	WORK HOURS 工时
	<p>2、PULLEY,STARTER.....0.2H</p> <p>2、启动杯.....0.2H</p> <p>3、IMPELLER.....0.2H</p> <p>3、叶轮.....0.2H</p> <p>4、FLYWHEEL SUBASSEMBLY.....0.3H</p> <p>4、飞轮组合.....0.</p>

				3H 5、COIL, IGNITION.....0.2H 5、点火线 圈..... .0.2H		
REF. NO. 序号	PART NO 物料代码	CHINSES 中文名	DESCRIPTION 英文名	Q'TY 数量	包装数	备注
E15-1	13501-Z010110-0000	飞轮螺母	NUT	1	1	
E15-2	28002-Z300210-0000	起动杯	PULLEY,STARTER	1	1	
E15-3	19352-Z440110-0000	叶轮	IMPELLER	1	1	
E15-4	13510-Z440110-0000	飞轮组合	FLYWHEEL SUBASSEMBLY	1	1	
E15-5	30400-Z440110-0100	点火线圈	COIL, IGNITION	1	1	
E15-6	90001-0625-01	六角法兰面螺栓-小系列	BOLT	2	1	
FIG.14 CONTROL ASSY, THROTTLE (E13)						
图 14 : 油门操纵部件 (E13)						
				WORK HOURS 工时		

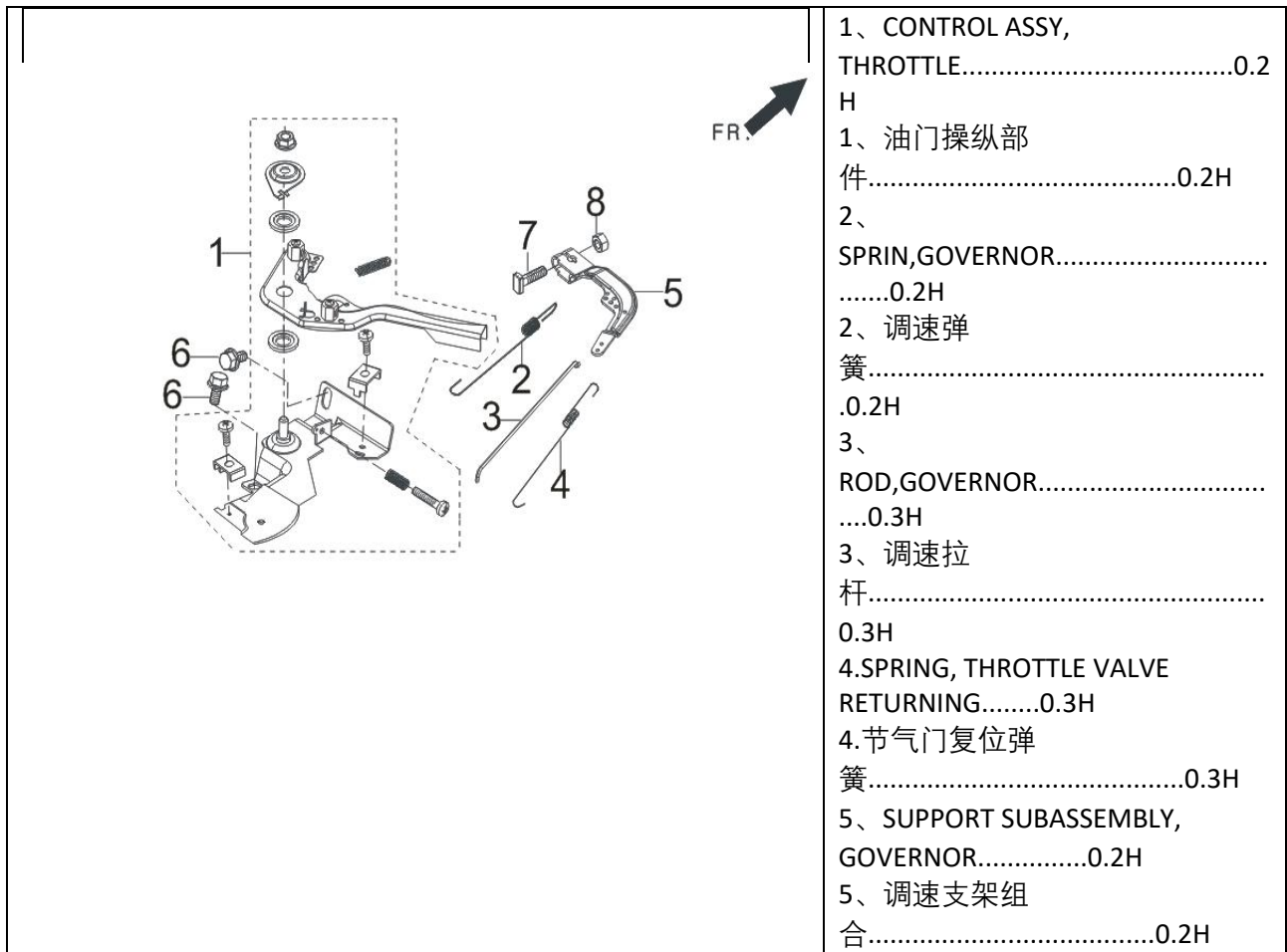

- 1、CONTROL ASSY,
THROTTLE.....0.2
H
- 1、油门操纵部
件.....0.2H
- 2、
SPRIN,GOVERNOR.....
.....0.2H
- 2、调速弹
簧.....
.0.2H
- 3、
ROD,GOVERNOR.....
....0.3H
- 3、调速拉
杆.....
0.3H
- 4.SPRING, THROTTLE VALVE
RETURNING.....0.3H
- 4.节气门复位弹
簧.....0.3H
- 5、SUPPORT SUBASSEMBLY,
GOVERNOR.....0.2H
- 5、调速支架组
合.....0.2H

REF. NO. 序号	PART NO 物料代码	CHINSES 中文名	DESCRIPTION 英文名	Q'TY 数量	包装数	备注
E13-1	16520-Z010230-0000	油门操纵组合	CONTROL ASSY, THROTTLE	1	1	
E13-2	16063-Z010110-0000	调速弹簧	SPRING, GOVERNOR	1	1	
E13-3	16062-Z010110-0000	调速拉杆	ROD, GOVERNEOR	1	1	
E13-4	16012-Z010110-0000	节气门复位弹簧	SPRING, THROTTLE VALVE RETURNING	1	1	
E13-5	16070-Z010110-0000	调速支架组合	SUPPORT SUBASSEMBLY, GOVERNOR	1	1	
E13-6	90001-0610-01	六角法兰面螺栓	BOLT	2	1	
E13-7	16072-Z010110-0000	调速支架固定螺栓	BOLT, GOVERNOR SUPPORT	1	1	
E13-8	90305-0600-31	六角法兰面螺母	NUT	1	1	

图 15: 泵体组件 (F68)

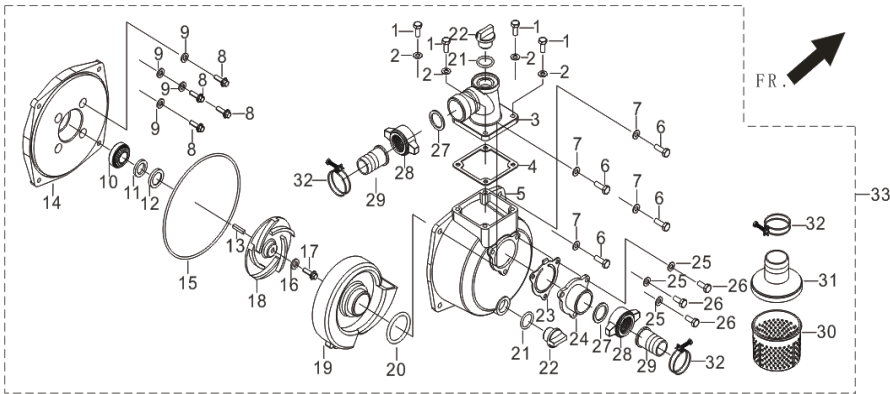

WORK HOURS 工时

3、OUTLET, WATER.....	0.1H
3、出水 口.....	0.1H
5、PUMP BODY.....	0.2H
5、泵 体.....	0.2H
10、SEAL ASSY, MECHANISM.....	0.5H
10、机械密封部 件.....	0.5H
14、JOINT, WATER PUMP.....	0.6H
14、水泵连接 盘.....	0.6H
18、IMPELLER, WATER PUMP.....	0.2H
18、水泵叶 轮.....	0.2H
19、CASE, WHORL.....	0.2H
19、涡 壳.....	0.2H
20、RIGN, WHORL CASE SEALING.....	0.2H
20、涡壳密封 圈.....	0.2H
11、陶瓷密 封.....	0.5H
12、 WASHER.....	0.5H

				12、叶轮密封 圈..... .0.5H 23、GASKET, INLET WATER.....0.1H 23、进水口密封 垫.....0. 1H 24、INLET, WATER..... .0.1H 24、进水 口.....0.1H 33、PUMP ASSY, WATER.....0.6H 33、水泵部 件.....0.6H
--	--	--	--	---

REF. NO. 序号	PART NO 物料代码	CHINSES 中文名	DESCRIPTION 英文名	Q'TY 数量	包装数	备注
F68-1	90005-0820-01	六角头螺栓-全螺纹	BOLT	4	1	
F68-2	90408-0800-01	平垫圈-A级	WASHER	4	1	
F68-3	70108-V010310-0000	出水口	OUTLET, WATER	1	1	
F68-4	70109-V010210-0000	出水口密封垫	GASKET, OUTLET	1	1	
F68-5	70105-V010210-0000	泵体	PUMP BODY	1	1	
F68-6	90005-0825-01	六角头螺栓-全螺纹	BOLT	4	1	
F68-7	90408-0800-01	平垫圈-A级	WASHER	4	1	
F68-8	90007-V010210-0000	六角法兰面螺栓-加大系列-B级	BOLT	4	1	

F68-9	90409-V010210-0000	密封垫圈	WASHER	4	1	
F68-10	70300-V010210-0000	机械密封部件	SEAL ASSY, MECHANISM	1	1	
F68-11	70309-V010210-0000	陶瓷密封	SEAL,PORCELAIN	1	1	
F68-12	70125-V010210-0000	叶轮密封圈	WASHER	1	1	
F68-13	90522-V010210-0000	普通平键	KEY	1	1	
F68-14	70118-V010410-0000	水泵连接盘	JOINT, WATER PUMP	1	1	
F68-15	70119-V010210-0000	水泵连接盘垫	CUSHION, WATER PUMP JOINT	1	1	
F68-16	90409-V010210-0000	密封垫圈	WASHER	1	1	
F68-17	90007-V010110-0000	六角法兰面螺栓-加大系列-B级	BOLT	1	1	
F68-18	70102-V010410-0000	水泵叶轮	IMPELLER, WATER PUMP	1	1	
F68-19	70103-V010210-0000	涡壳	CASE, WHORL	1	1	
F68-20	70104-V010210-0000	涡壳密封圈	RIGN, WHORL CASE SEALING	1	1	
F68-21	70122-V010210-0000	螺塞垫圈	WASHER, SCREW PLUG	2	1	
F68-22	70107-V010210-0000	螺塞	PLUG, THREAD	2	1	
F68-23	70115-V010210-0000	进水口密封垫	GASKET, INLET WATER	1	1	
F68-24	70116-V010310-0000	进水口	INLET, WATER	1	1	
F68-25	90408-0800-01	平垫圈-A级	WASHER	3	1	

F68-26	90005-0820-01	六角头螺栓-全螺纹	BOLT	3	1	
F68-27	70131-V010210-0000	软管接头密封圈	RING, HOSE JOINT SEAL	2	1	
F68-28	70111-V010310-0000	软管接头	JOINT, HOSE	2	1	
F68-29	70112-V010210-0000	软管接口	INTERFACE, HOSE	2	1	
F68-30	70114-V010210-0000	滤网	FILTER	1	1	
F68-31	70113-V010210-0000	滤网盖	COVER, FILTER	1	1	
F68-32	70400-V010210-0000	软管箍部件	HOOP ASSY, HOSE	3	1	
F68-33	70100-V010810-0K00	水泵部件	PUMP ASSY, WATER	1	1	

FIG.16 FRAME ASSY, ENGINE 机架部件(F61)

				WORK HOURS 工时		
				1、FRAME ASSY, ENGINE.....0.5H 1、机架部件.....0.5H 3、SEAT, ENGINE FRAME SHOCK ABSORPTION.....0.1H 3、机架减震座.....0.1H 6、DECORATIVE FRAME.....0.1H 6、机架装饰板.....0.1H		
REF. NO. 序号	PART NO 物料代码	CHINSES 中文名	DESCRIPTION 英文名	Q'TY 数量	包装数	备注
E16-1	51100-V020910-H7L0	机架部件	FRAME ASSY, ENGINE	1	1	

E16-2	90001-0610-01	六角法兰面螺栓	BOLT	4	1	
E16-3	51014HY450110-0000	机架减震座	SEAT, ENGINE FRAME SHOCK ABSORPTION	4	1	
E16-4	90327-0800-31	六角法兰面螺母	NUT	8	1	
E16-5	90001-0850-01	六角法兰面螺栓	BOLT	4	1	
E16-6	51025-V020210-H700	机架装饰板	DECORATIVE FRAME	1	1	
E16-7	90001-0612-01	六角法兰面螺栓	BOLT	4	1	